

DATE	M'K	REVISIONS	DWN	APPR	REMARKS

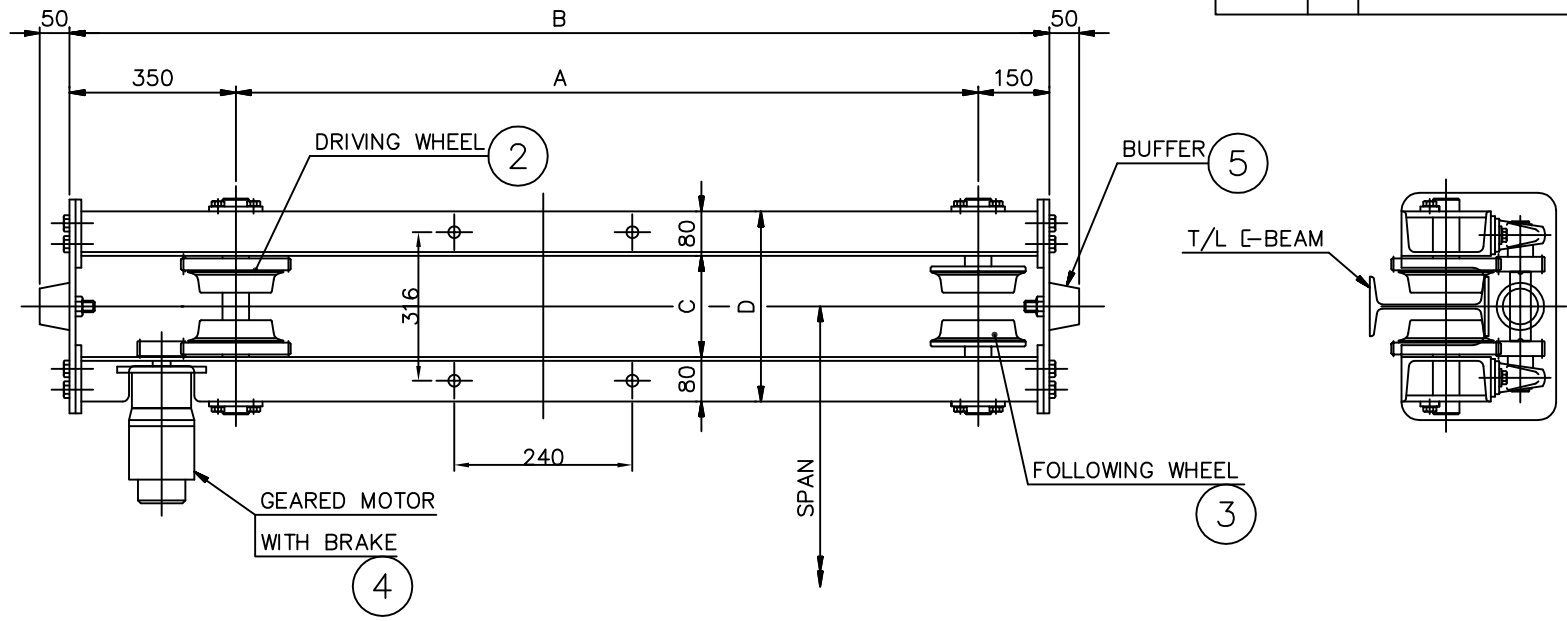

	A	B
1	1250	1750
2	1500	2000
3	1750	2250
4	2000	2500
5	2250	2750
6	2500	3000

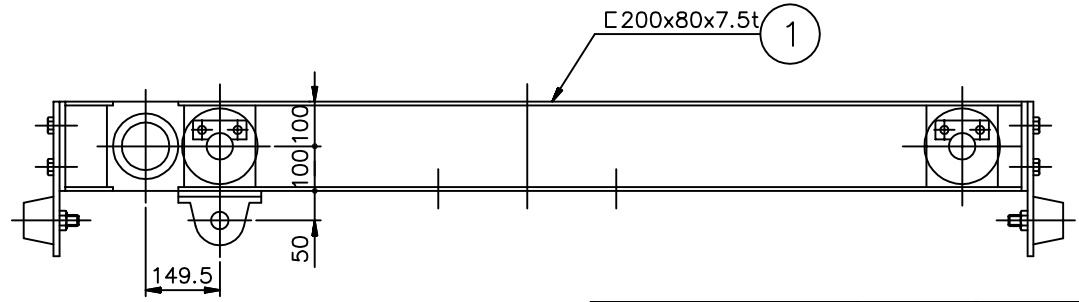

T.L.I-BEAM \ NOTATION	C	D
I 250x125x7.5t	201	361
I 300x150x10t	226	386
I 400x150x10t	226	386
I 400x150x12.5t	226	386
I 450x175x13t	251	411
I 450x175x13t	266	426
H500x200x10/16t	270	436

SPECIFICATION	
SPEED	16 M/MIN
MOTOR	0.75 KW x 4P
POWER SOURCE	AC 3φ $\begin{matrix} 220 \\ 380 \\ 440 \end{matrix}$ V 60 Hz
REMARKS	

SPEED CALCULATION
 $1710 \times 1/16.3 \times 17/56 \times 0.16 \times 3.14 = 16 \text{ M/MIN}$

5	BUFFER	RUBBER	4				
4	GEARED MOTOR	-	2				
3	FOLLOWING WHEEL	-	4				
2	DRIVING WHEEL	-	4				
1	SADDLE FRAME	SS41	2				
	ASS'Y OF SADDLE	-	1SET				
NO	DESCRIPTIONS	MT'L	SET QTY	SET	UNIT WEIGHT KG	TOTAL WEIGHT KG	REMARKS

PROJECT					DATE
					2015.12
TITLE	GSC - ø160 (I-BEAM)				SCALE
	ASS'Y OF SADDLE				1/10
DRAWN	DESIGNED	CHECKED	APPROVED	REF DRAWING	

진도호이스트크레인(주)				DRAWING NO.	
				GFS-160-SADDLE	

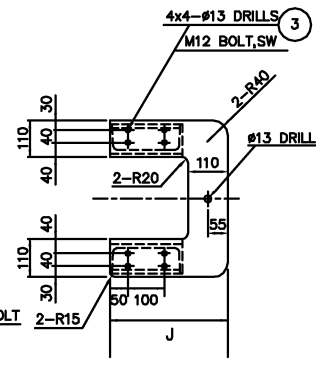
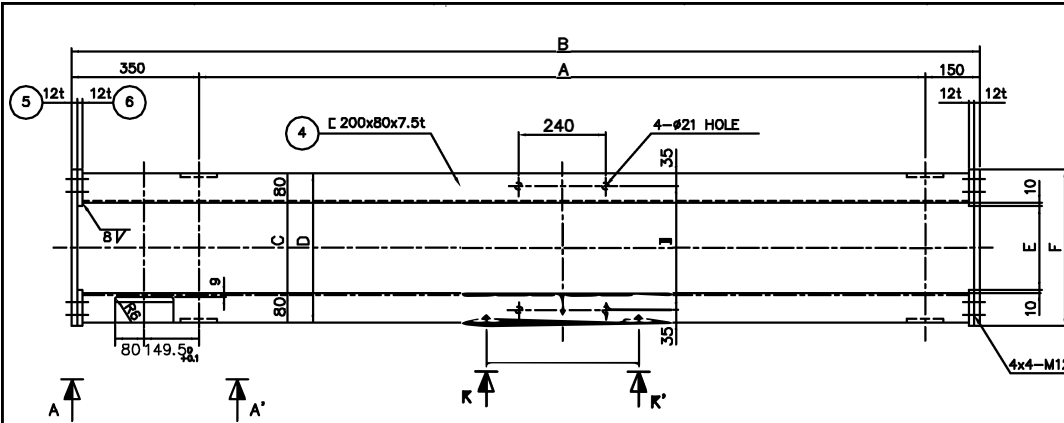

NO.	DESCRIPTIONS	MAT'L	Q'TY	WEIGHT KG		REMARKS.
				UNIT	TOTAL	
	SADDLE	—	2			
1	BOLT.SW	PUR.	8			M12x35Lx20S
2	BOLT.SW		8			M12x30Lx20S
3	BOLT.SW	PUR.	32			M12x30Lx20S
4	C 200x80x7.5t	SS41	4			L=2452
5	12tx325x F		4			
6	6tx110x200		8		16.5	
7	15tx160x200		2		5	
8	9tx60x160		4		2.5	
9	9tx100x200		8		11.5	
10	12tx80x200	SS41	4		6	

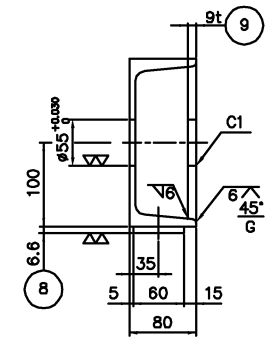
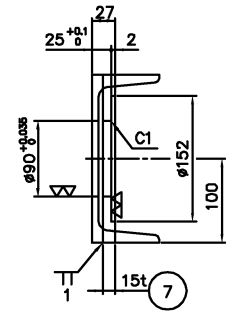
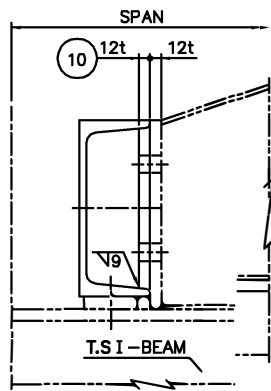
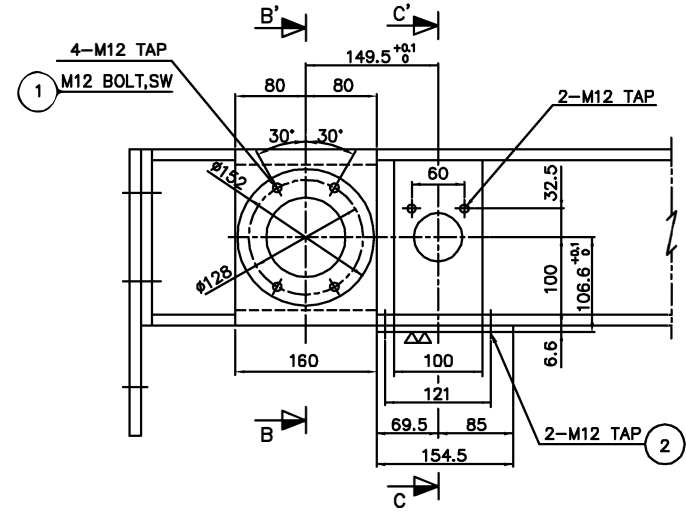

VIEW A-A'

VIEW K-K'

SECTION B-B'

SECTION C-C'

	A	B
1	1250	1750
2	1500	2000
3	1750	2250
4	2000	2500
5	2250	2750
6	2500	3000

NOTATION		C	D	E	F	I	J
T.L I - BEAM							
I-250x125x7.5t		201	361	181	401	291	325
I-300x150x10t		226	386	206	426	316	335
I-400x150x12.5t		226	386	206	426	316	335
I-450x175x13t		251	411	231	451	341	340
I-600x190x13t		266	426	246	466	356	340
H-BEAM 200		276	436	256	476	366	

NOTE

1. 제작수량 2SETS, 대칭제작할 것.
2. 상기수량 1 SET분 물량임.
3. 지시없는 용접부위는 양은 모재 두께의 70% 필렛용접할 것.
4. 체결볼트는 상대부품과 동시가공할 것.

MULTI UNITS	SCALE	PROJECT NO.	SYSTEM ID	ORGA. CODE	TYPE	SERIAL NO.	AF-NO.	SHEET	REV.
9	NONE	8900	71840	TM	설치시 용조	제3차 일차비표		1	A